

Aqara

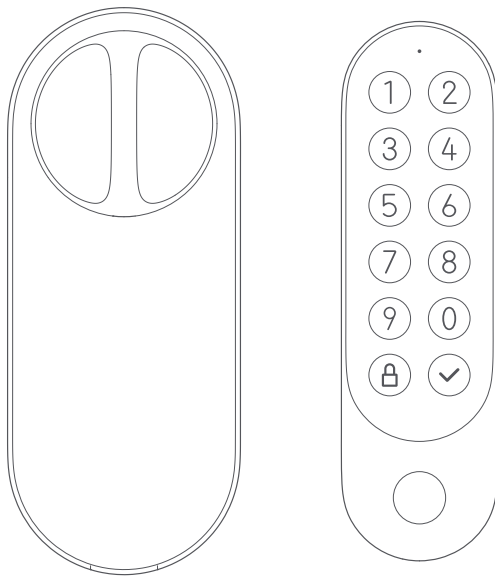

Smart Lock U200 User Manual **EU**

Product Introduction

The U200 represents the next step in terms of both ease of use and functionality. Equipped with Matter over Thread support, it ensures seamless interoperability across a broad range of smart home ecosystems*. The U200 is designed to offer the convenience of keyless access to as many users as possible without compromising on cutting-edge features. Unlike previous solutions, it operates the existing lock cylinder and does not require drilling or modifying the door.

* To experience smart automations and other related functions, a 2-in-1 Matter Controller and Thread Border Router are required.

What's in the Box

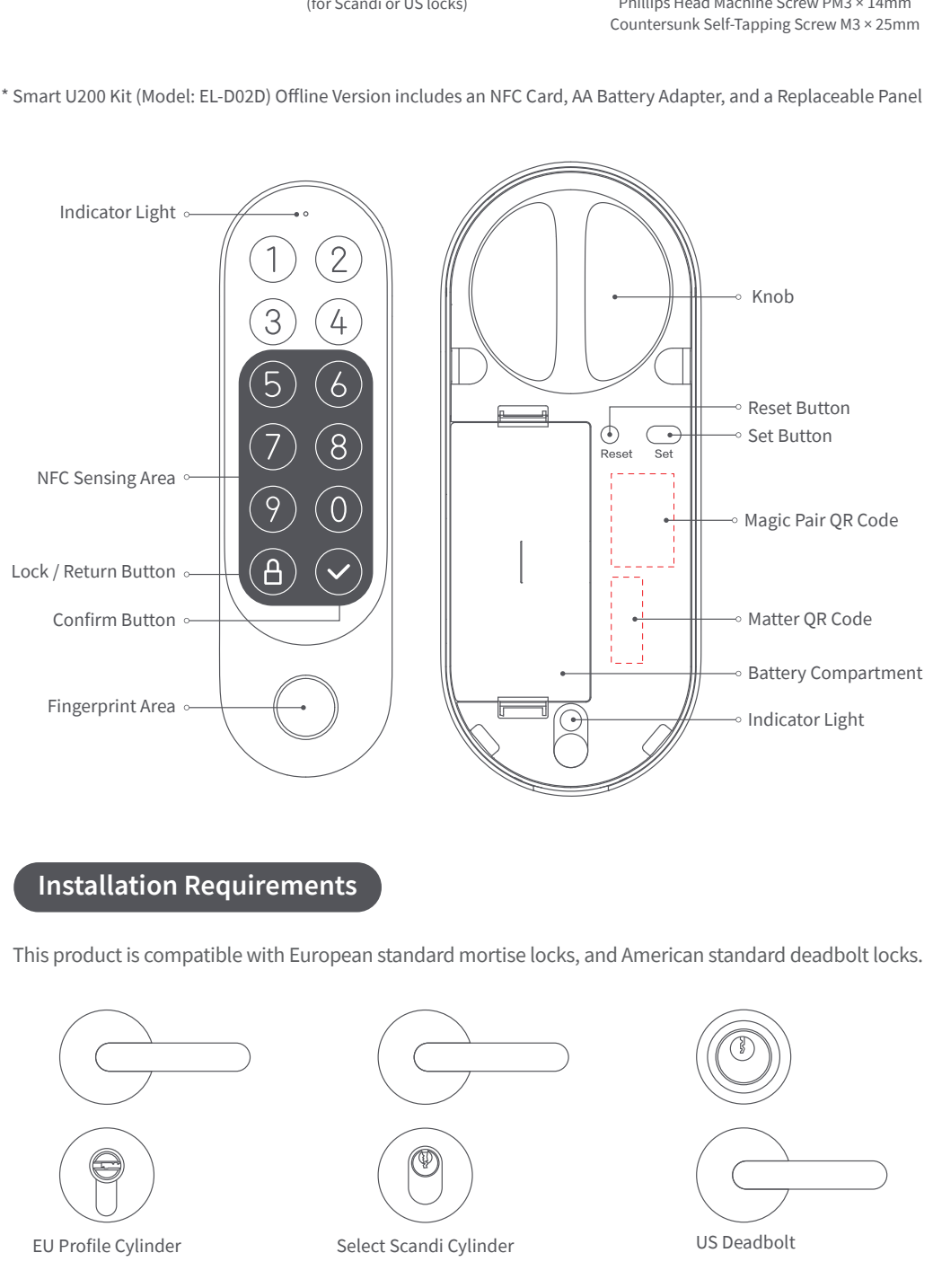

* Smart U200 Kit (Model: EL-D002D) Offline Version includes an NFC Card, AA Battery Adapter, and a Replaceable Panel

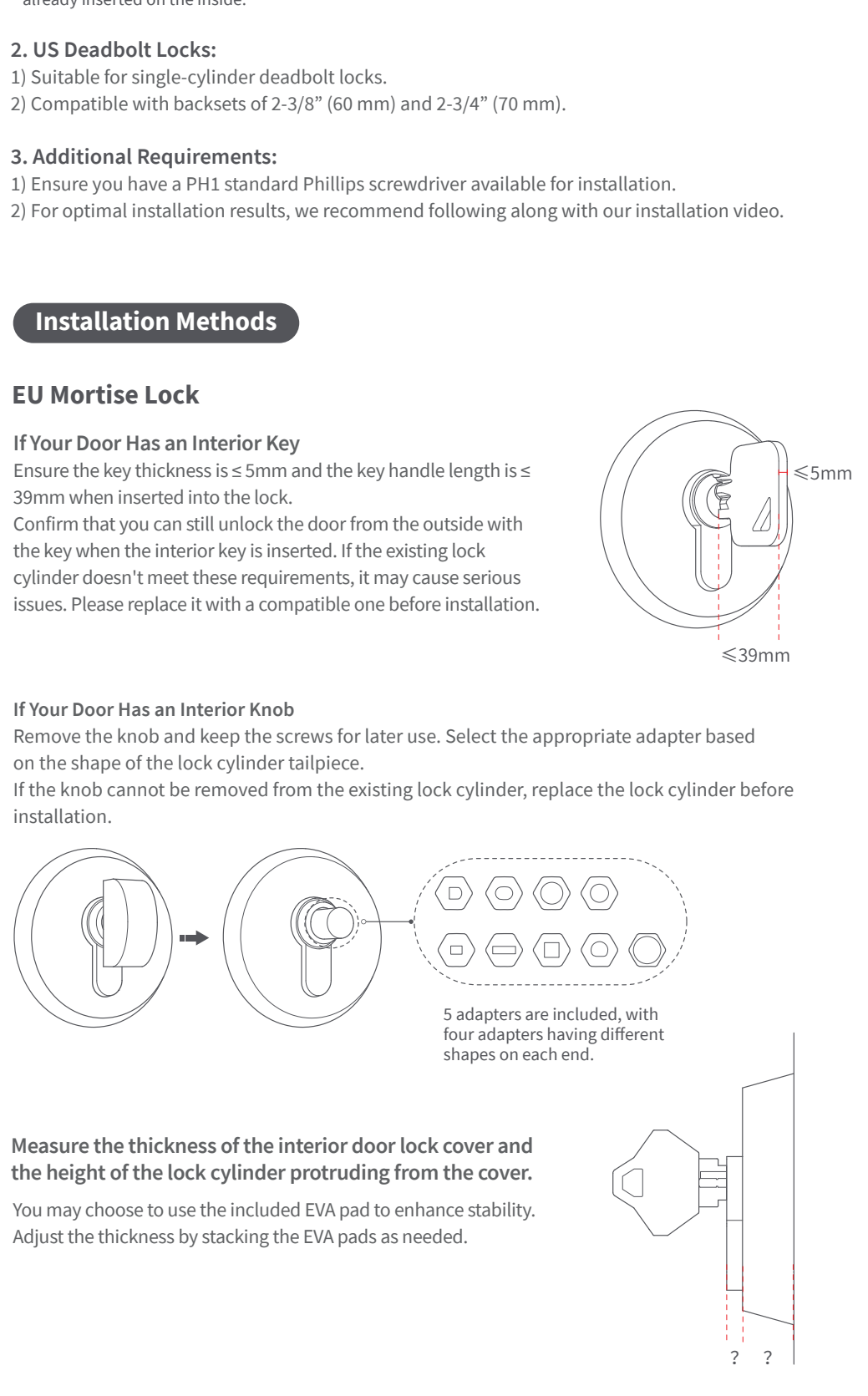

Installation Requirements

This product is compatible with European standard mortise locks, and American standard deadbolt locks.

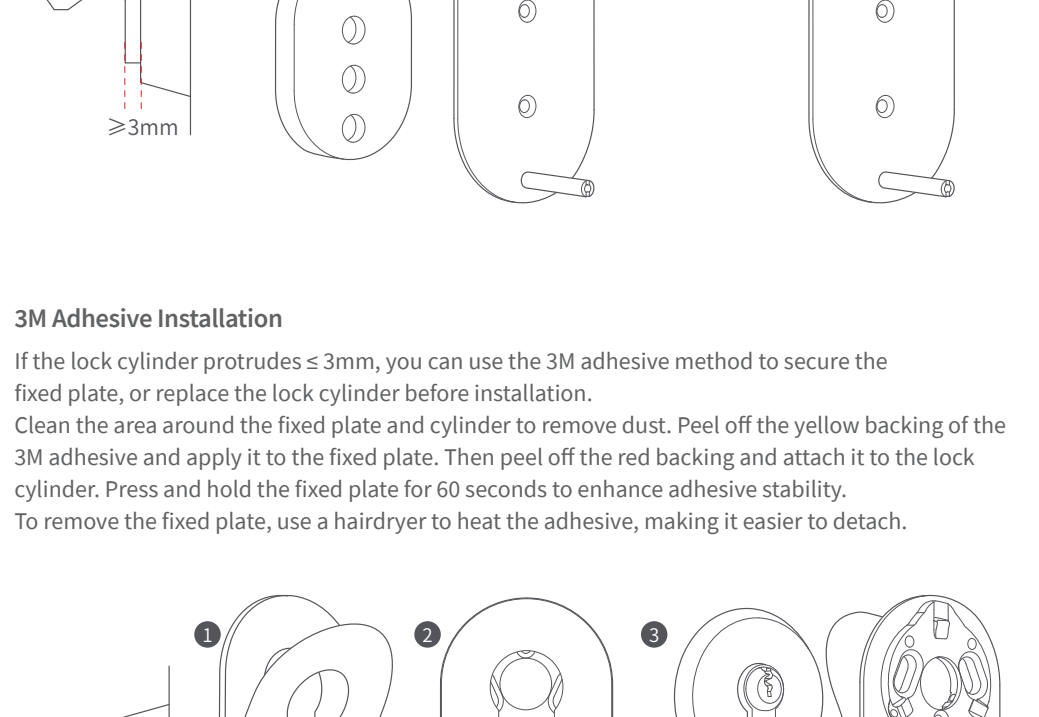

* Check this website for compatibility issues: <https://www.aqara.com/en/u200-installation-methods>

- 1. Euro Mortise Locks:**
 - 1) Supports Euro profile and select Scandi cylinders.
 - 2) Ensure your cylinder includes an Emergency Function**.

** An Emergency Function enables the cylinder to be unlocked from the outside using a key, even if another key is already inserted on the inside.
- 2. US Deadbolt Locks:**
 - 1) Suitable for single-cylinder deadbolt locks.
 - 2) Compatible with backsets of 2-3/8" (60 mm) and 2-3/4" (70 mm).
- 3. Additional Requirements:**
 - 1) Ensure you have a PH1 standard Phillips screwdriver available for installation.
 - 2) For optimal installation results, we recommend following along with our installation video.

Installation Methods

EU Mortise Lock

If Your Door Has an Interior Key
Remove the knob and the key handle length is ≤ 39mm when inserted into the lock. Confirm that you can still unlock the door from the outside with the key when the interior key is inserted. If the existing lock cylinder doesn't meet these requirements, it may cause serious issues. Please replace it with a compatible one before installation.

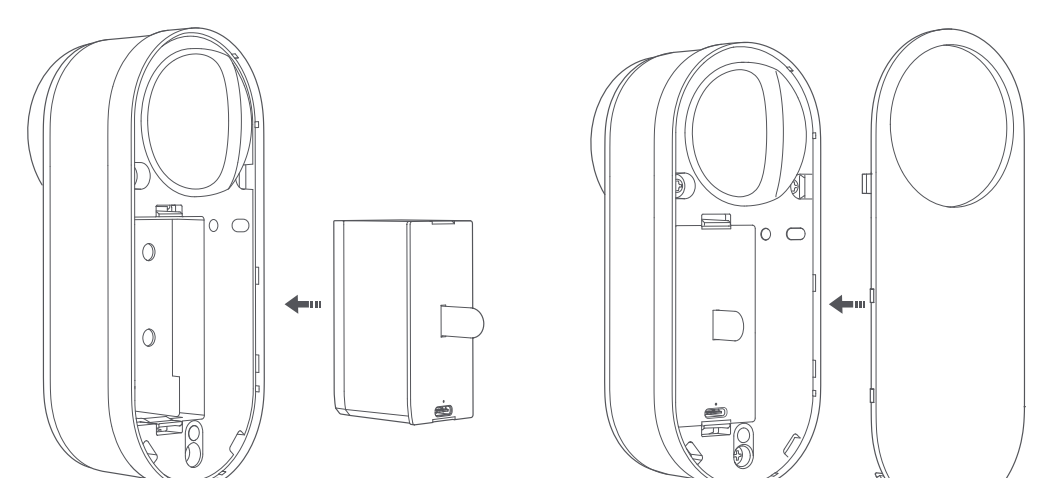

If Your Door Has an Interior Knob
Remove the knob and keep the screws for later use. Select the appropriate adapter based on the shape of the lock cylinder tailpiece. If the knob cannot be removed from the existing lock cylinder, replace the lock cylinder before installation.

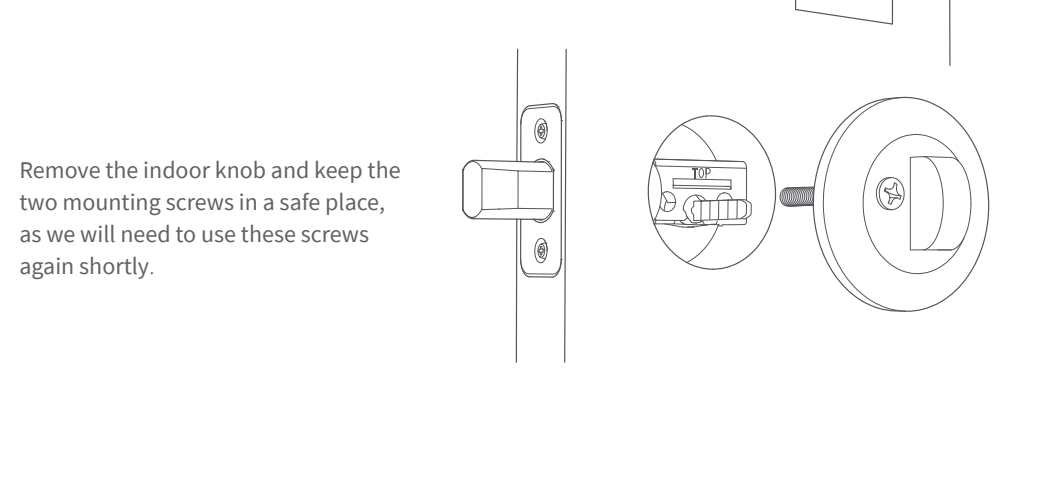

Measure the thickness of the interior door lock cover and the height of the lock cylinder protruding from the cover.
You may choose to use the included EVA pad to enhance stability. Adjust the thickness by stacking the EVA pads as needed.

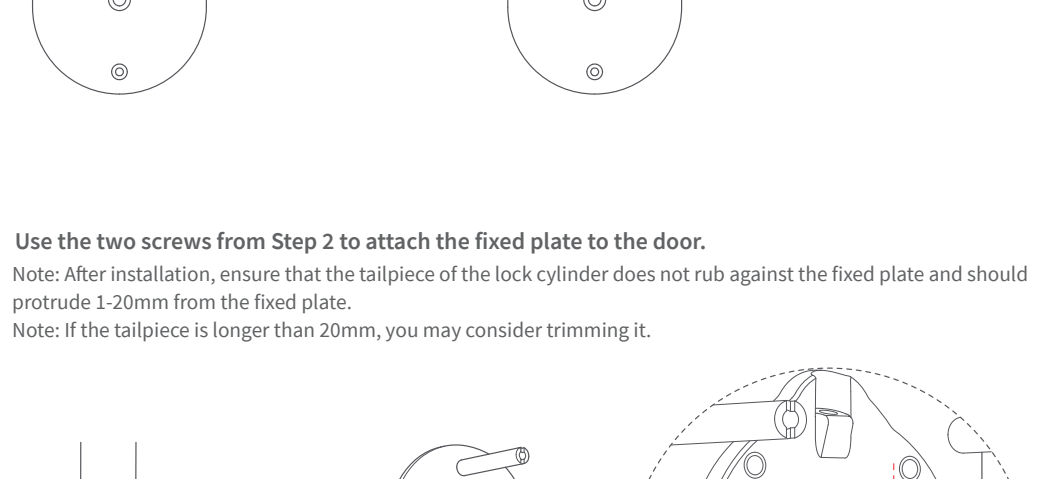

Screw Installation
If the lock cylinder protrudes ≥ 3mm, you can secure the fixed plate using screws. Use the provided hex key to tighten the three screws clockwise to secure the lock to the cylinder. Over-tightening may affect the lock cylinder's performance, causing issues with locking and unlocking. Note: After removing the fixed plate, pre-tighten the screws by turning them 10 times clockwise to speed up the installation process.

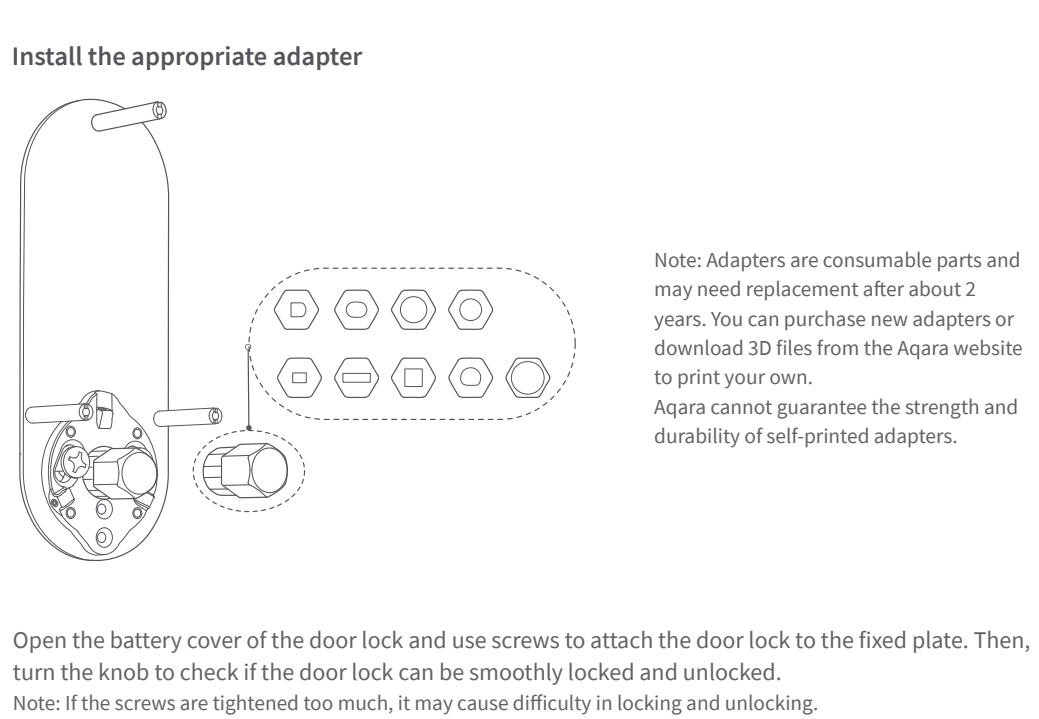

3M Adhesive Installation
If the lock cylinder protrudes ≤ 3mm, you can use the 3M adhesive method to secure the fixed plate, or replace the lock cylinder before installation. Clean the area around the fixed plate and cylinder to remove dust. Peel off the yellow backing of the 3M adhesive and apply it to the fixed plate. Then peel off the red backing and attach it to the lock cylinder. Press and hold the fixed plate for 60 seconds to enhance adhesive stability. To remove the fixed plate, use a hairdryer to heat the adhesive, making it easier to detach.

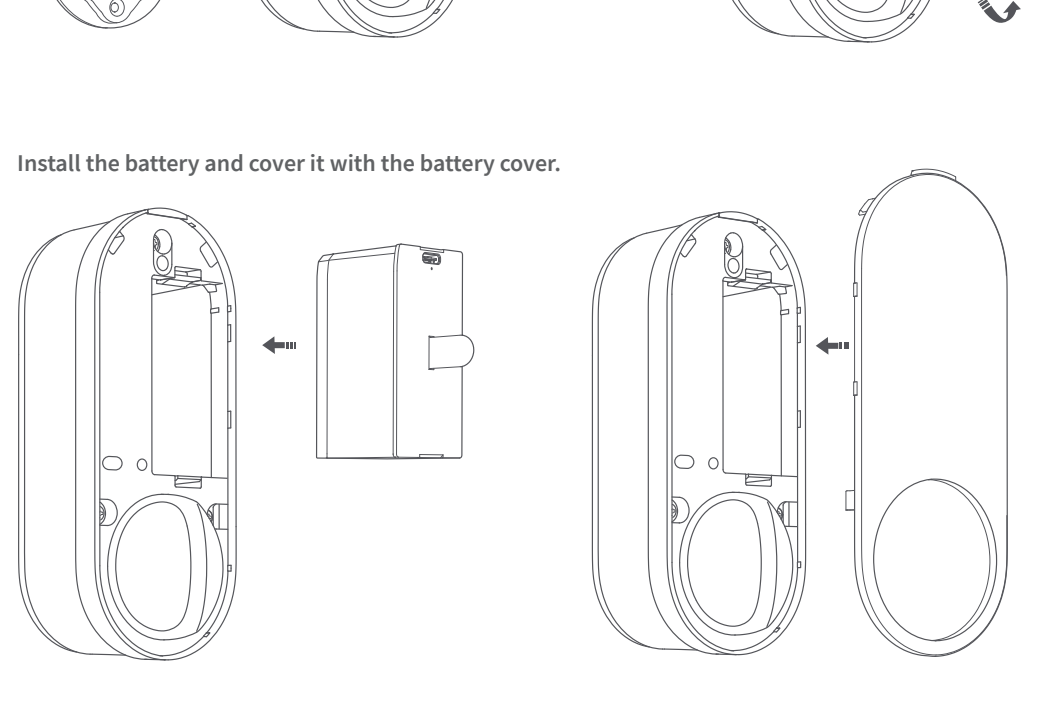

Installing the Key or Adapter
If your knob tailpiece is cylindrical, use the original knob screws to secure the adapter.

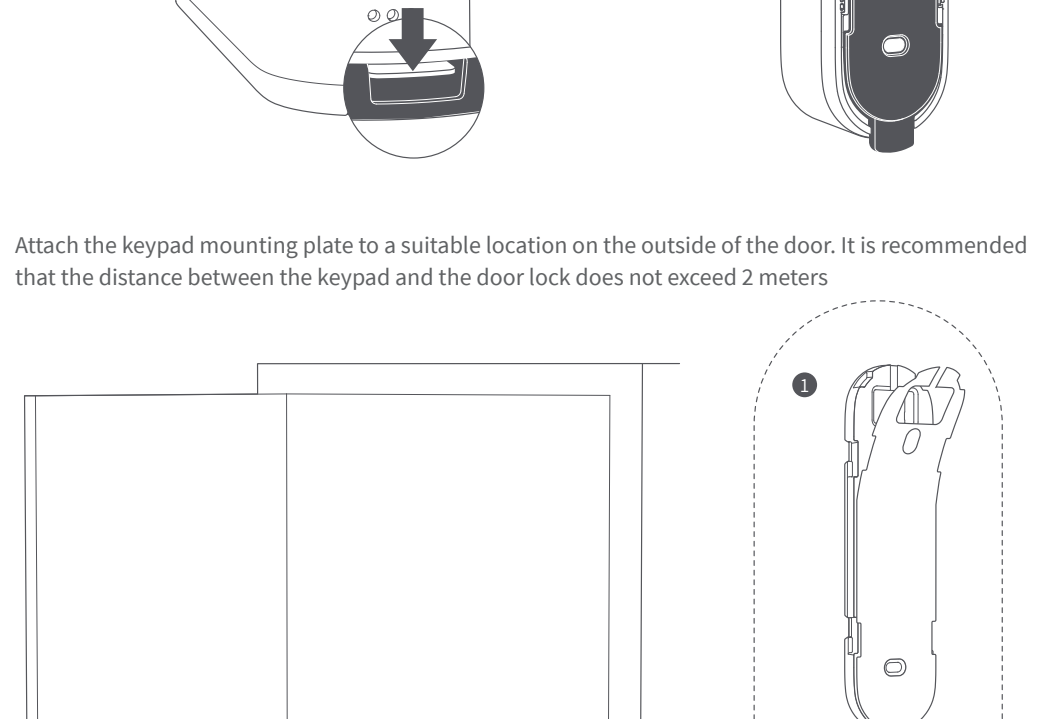

Note: Adapters are consumable parts and may need replacement after about 2 years. You can purchase new adapters or download 3D files from the Aqara website to print your own. Aqara cannot guarantee the strength and durability of self-printed adapters.

Open the battery cover and secure the lock to the fixed plate with screws. Rotate the knob to ensure smooth locking and unlocking. Adjust the screw tightness if necessary to avoid operational issues.

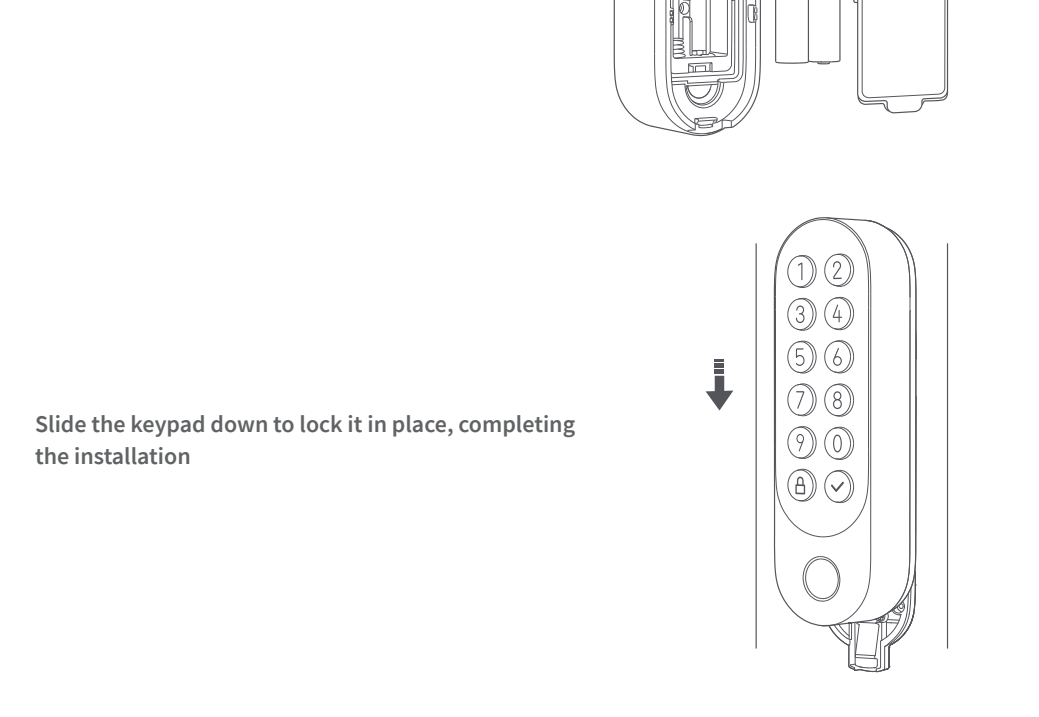

Insert the batteries, cover the battery plate, and complete the lock installation. Next, proceed with the keypad installation.

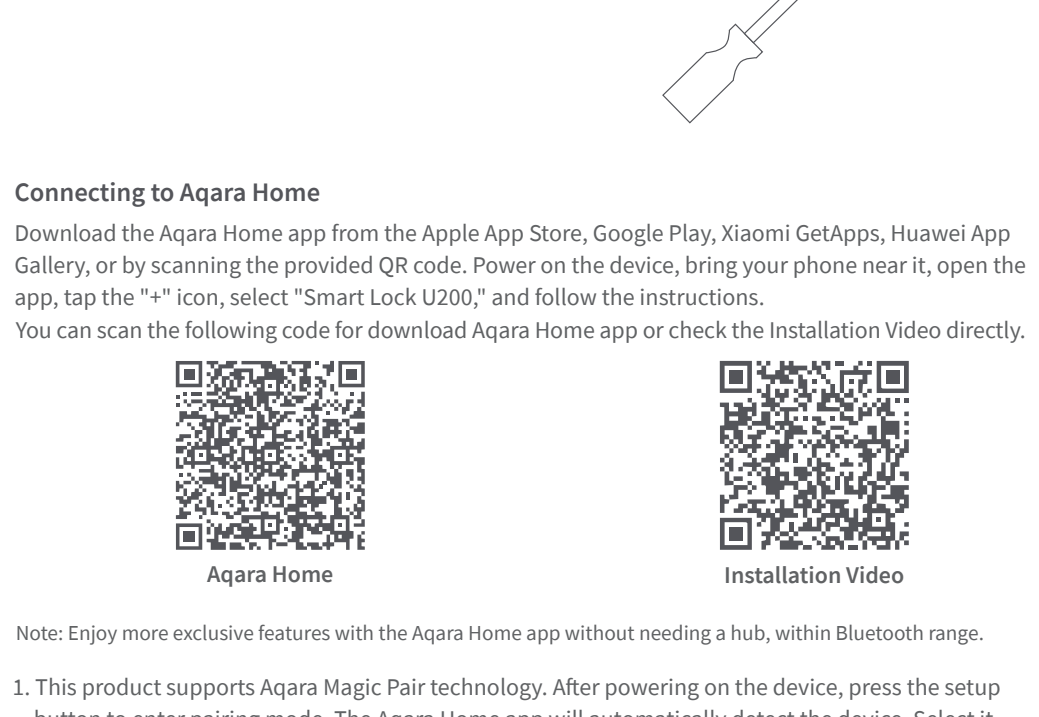

US Deadbolt Lock

Before installation, it is recommended to use tape to secure the outdoor part of the door lock.

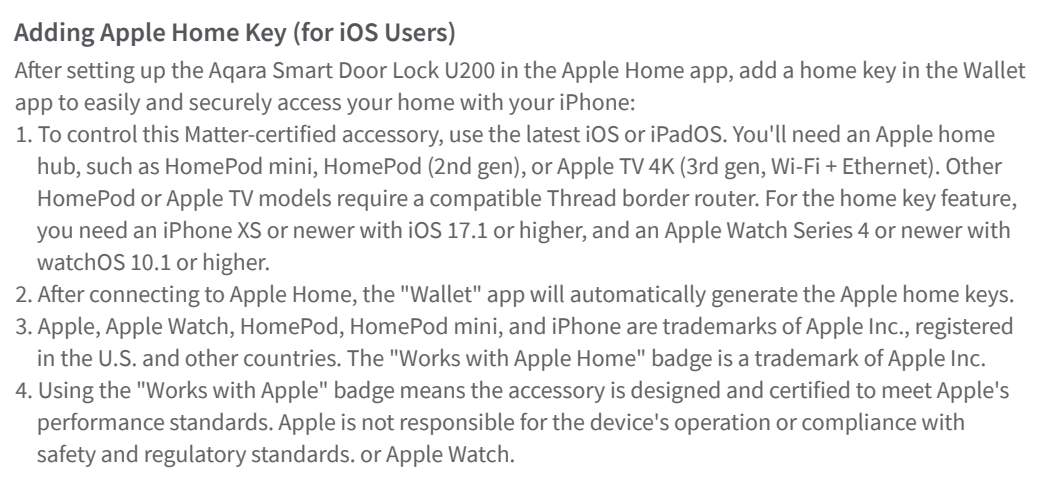

Remove the indoor knob and keep the two mounting screws in a safe place, as we will need to use these screws again shortly.

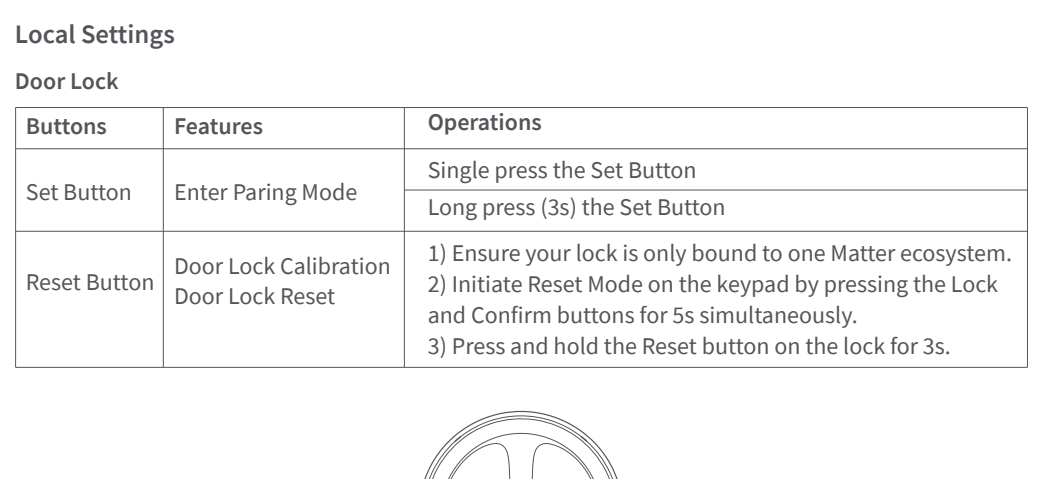

Remove the fixed plate accessory, rotate it 180 degrees, and reinstall it. Depending on the distance between the screw holes, you might need to use a different accessory.

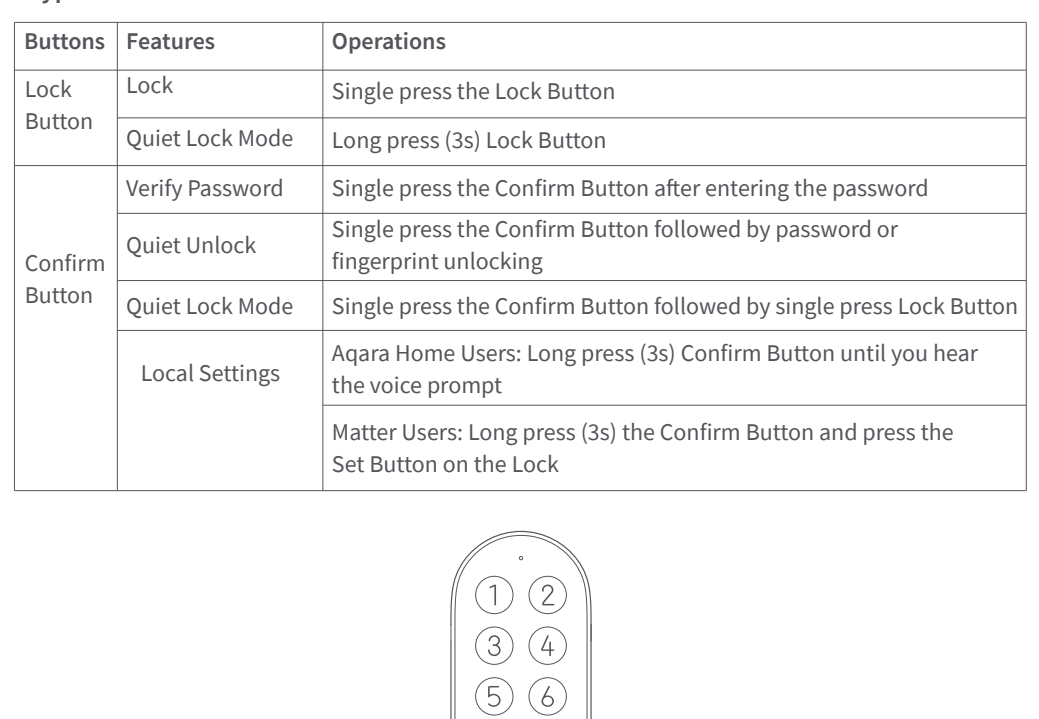

Use the two screws from Step 2 to attach the fixed plate to the door.
Ensure the key tailpiece is ≤ 20mm. Note: If the tailpiece is longer than 20mm, you may consider trimming it.

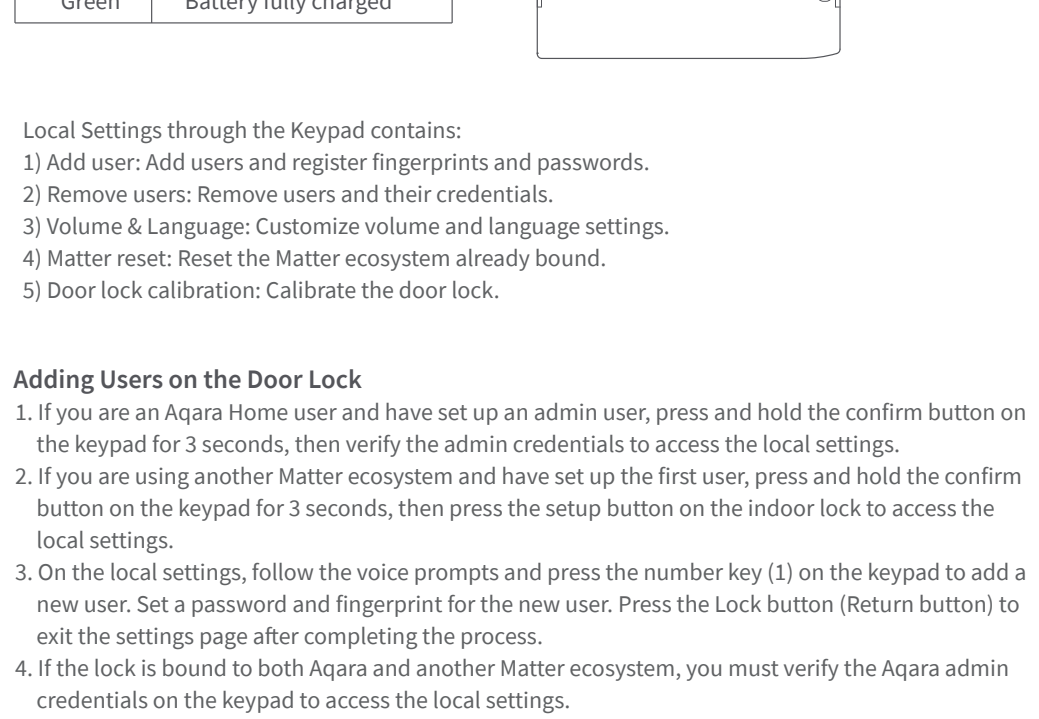

Install the appropriate adapter

Open the battery cover of the door lock and use screws to attach the door lock to the fixed plate. Then, turn the knob to check if the door lock can be smoothly locked and unlocked. Note: If the screws are tightened too much, it may cause difficulty in locking and unlocking. Please adjust the screw tightness accordingly.

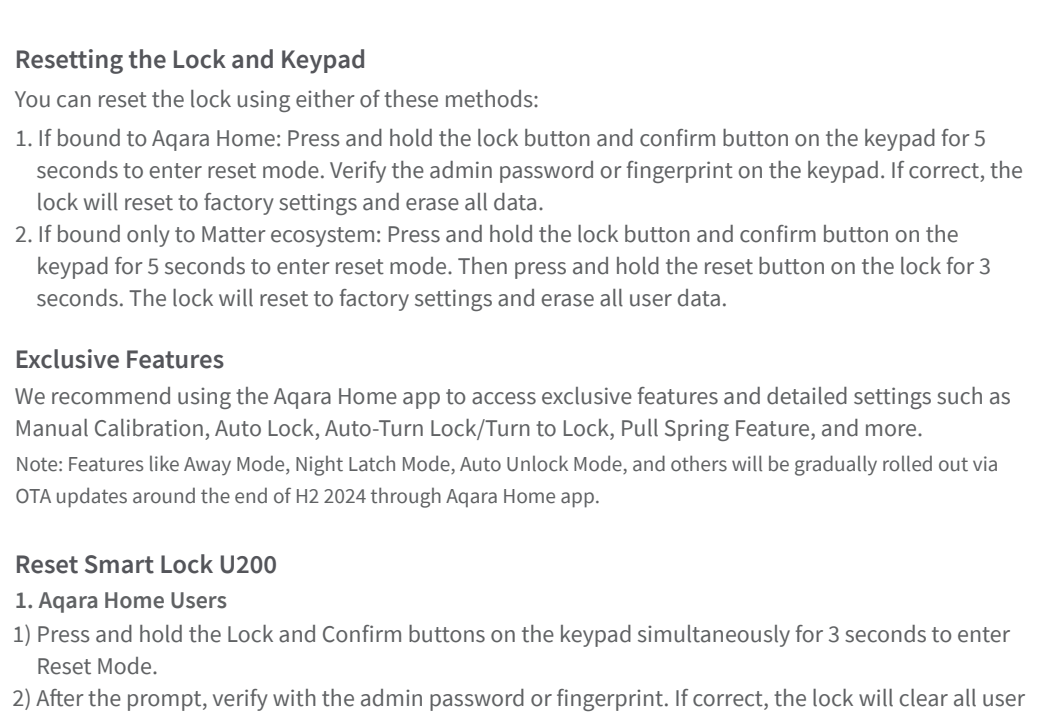

Install the battery and cover it with the battery cover.

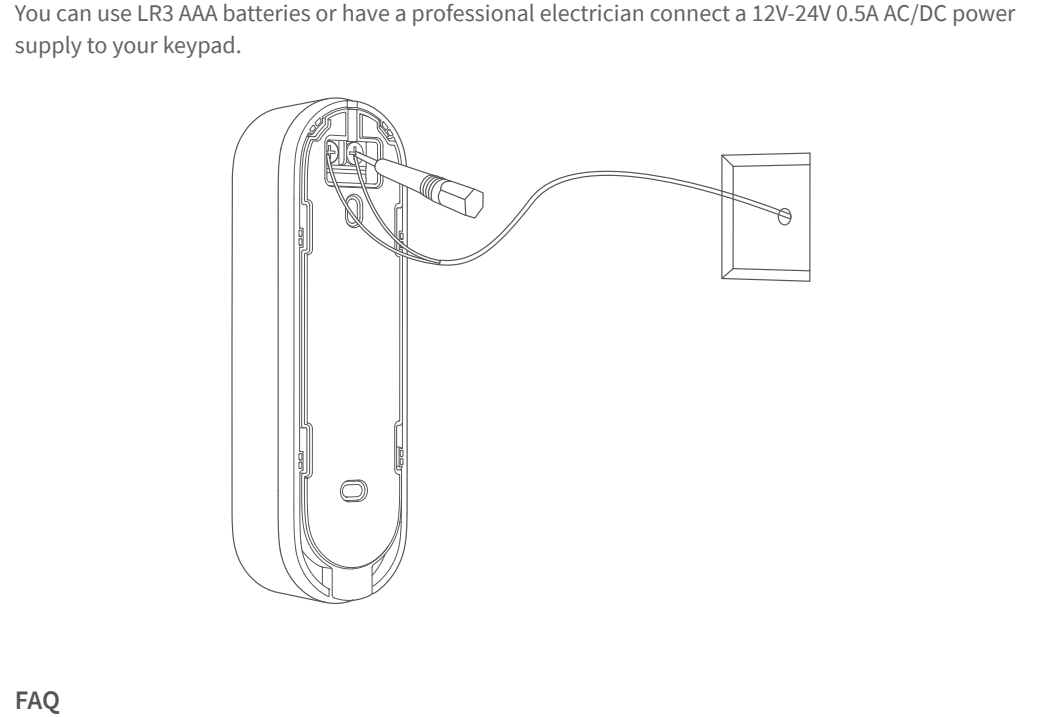

Keypad

Use a tool to press down on the metal clip beneath the keypad, then push upward to separate the keypad from the mounting plate.

Attach the keypad mounting plate to a suitable location on the outside of the door. It is recommended that the distance between the keypad and the door lock does not exceed 2 meters

Insert AAA batteries into the keypad

Slide the keypad down to lock it in place, completing the installation

If you want to remove the keypad:
Use a tool to press down on the metal clip beneath the keypad, then push upward to separate the keypad from the mounting plate. Insert AAA batteries into the keypad, then slide the keypad down to lock it in place, completing the installation.

Note: If you have already bound the door lock to the Aqara Home app or a third-party Matter ecosystem, you will need to verify the Aqara administrator password or fingerprint, or press the reset button on the door lock to disable the alarm. Otherwise, the keypad will continue to emit an alarm sound.

Connecting to Aqara Home

Download the Aqara Home app from the Apple App Store, Google Play, Xiaomi GetApps, Huawei App Gallery, or by scanning the provided QR code. Power on the device, bring your phone near it, open the app, tap the "+" icon, select "Smart Lock U200", and follow the instructions. You can scan the following code to download Aqara Home app or check the Installation Video directly.

Note: Enjoy more exclusive features with the Aqara Home app without needing a hub, within Bluetooth range.

1. This product supports Aqara Magic Pair technology. After powering on the device, press the setup button to enter pairing mode. The Aqara Home app will automatically detect the device. Select it and follow the app instructions to complete setup.
2. Keep your phone close to the device during pairing. Ensure your phone is connected to the internet and Bluetooth is enabled.
3. Follow the app instructions to scan the QR code on the product or enter the 8-digit pairing code to confirm the addition of the device.

Connecting to other Matter Ecosystems

1. Ensure you have a 2-in-1 Matter Controller and Thread Border Router for third-party ecosystems for the binding. Power on the door lock, press the Set button to enter pairing mode, then use the third-party app to scan the Matter QR code or enter the setup code from the Lock or user manual.
2. To add the device to another ecosystem after binding it to Matter, use the Matter app to share the device with other platforms.
3. If you want to bind the device to another ecosystem and remove the current one, first remove the device from the app, then reset the door lock or go to the local settings page to reset the Matter ecosystem. The door lock will revert to its initial pairing mode. Refer to the Local Settings section of the manual for reset instructions.

Note: In the early stages of the Matter ecosystem, different platforms support varying features. For example, some platforms do not support adding door lock passwords. For a better user experience, we recommend adding the device in the Aqara Home app.

Adding Apple Home Key (for iOS Users)

After setting up the Aqara Smart Door Lock U200 in the Apple Home app, add a home key in the Wallet app to easily and securely access your home with your iPhone:

1. To control this Matter-certified accessory, use the latest iOS or iPadOS. You'll need an Apple home hub, such as HomePod mini, HomePod (2nd gen), or Apple TV 4K (3rd gen, Wi-Fi + Ethernet). Other HomePod or Apple TV models require a compatible Thread border router. For the home key feature, you need an iPhone XS or newer with iOS 17.1 or higher, and an Apple Watch Series 4 or newer with watchOS 10.1 or higher.
2. After connecting to Apple Home, the "Wallet" app will automatically generate the Apple home keys.
3. Apple, Apple Watch, HomePod, HomePod mini, and iPhone are trademarks of Apple Inc., registered in the U.S. and other countries. The "Works with Apple Home" badge is a trademark of Apple Inc.
4. Using the "Works with Apple" badge means that the accessory is designed and certified to meet Apple's performance standards. Apple is not responsible for the device's operation or compliance with safety and regulatory standards, or Apple Watch.

Lock Calibration

After installation, users can calibrate the door lock using the Aqara Home app or directly on the lock. Here's how to calibrate on the lock:

1. Close the door and unlock it from the inside. Press and hold the Set button on the lock for 3 seconds to start calibration.
2. The lock will beep twice, then rotate to the unlock and lock positions. It will play a tune when calibration is complete.

Note: Two beeps during calibration indicate failure. The lock won't function properly if calibration is incomplete. If calibration fails or is inaccurate, check if the mounting screws are too loose or tight and adjust them before retrying. If calibration issues persist, use the manual calibration feature in the Aqara Home app

Local Settings

Buttons	Features	Operations
Set Button	Enter Pairing Mode	Single press the Set Button
Reset Button	Door Lock Calibration Door Lock Reset	Long press (3s) the Set Button 1) Ensure your lock is only bound to one Matter ecosystem. 2) Initiate Reset Mode on the keypad by pressing the Lock and Confirm Buttons for 5s simultaneously. 3) Press and hold the Reset button on the lock for 3s.

Keypad

Buttons	Features	Operations
Lock Button	Lock	Single press the Lock Button
	Quiet Lock Mode	Long press (3s) Lock Button
Confirm Button	Verify Password	Single press the Confirm Button after entering the password
	Quiet Unlock	Single press the Confirm Button followed by password or fingerprint unlocking
Local Settings	Quiet Lock Mode	Single press the Confirm Button followed by single press Lock Button
		Aqara Home Users: Long press (3s) Confirm Button until you hear the voice prompt Matter Users: Long press (3s) the Confirm Button and press the Set Button on the Lock

Battery Indicator

Red	Low battery or charging	Indicator Light
Green	Battery fully charged	

Local Settings through the keypad contains:

- 1) Add user: Add users and register fingerprints and passwords.
- 2) Remove users: Remove users and their credentials.
- 3) Volume & Language: Customize volume and language settings.
- 4) Matter reset: Reset the Matter ecosystem already bound.
- 5) Door lock calibration: Calibrate the door lock.

Adding Users on the Door Lock

1. If you are an Aqara Home user and have set up an admin user, press and hold the confirm button on the keypad for 3 seconds, then verify the admin credentials to access the local settings.
2. If you are using another Matter ecosystem and have set up the first user, press and hold the confirm button on the keypad for 3 seconds, then press the setup button on the indoor lock to access the local settings.
3. On the local settings, follow the voice prompts and press the number key (1) on the keypad to add a new user. Set a password and fingerprint for the new user. Press the Lock button (Return button) to exit the settings page after completing the process.
4. If the lock is bound to both Aqara and another Matter ecosystem, you must verify the Aqara admin credentials on the keypad to access the local settings.

Quiet Lock and Unlock Mode

The U200 features Quiet unlock and lock functions locally:

1. Outdoor Quiet Unlock: Press the confirm button on the keypad, then complete the unlock verification. If successful, the lock will unlock quietly.
2. Outdoor Quiet Lock: Press the confirm button on the keypad, then press the lock button. The lock will lock quietly.

To use the following features, add the lock in the Aqara Home app and enable the auxiliary rotation feature in the settings:

1. Indoor Quiet Unlock: Slowly turn the door lock knob in the unlock direction for a Quiet unlock.
2. Indoor Quiet Lock: Slowly turn the door lock knob in the lock direction for a Quiet lock.

Note: Customize Quiet functions using the Aqara Home app.

Auto-Lock

To use the auto lock function, add the lock in the Aqara Home app and enable the auto lock feature in the settings. Please note:

1. You may need to calibrate the lock's open and close angles using the Aqara Home app before enabling this feature.
2. After closing the door, the lock will attempt to lock automatically. Ensure the lock is secure before leaving.
3. After extended use, you may need to recalibrate the lock's open and close angles.

Resetting the Lock and Keypad

You can reset the lock using either of these methods:

1. If bound to Aqara Home: Press and hold the lock button and confirm button on the keypad for 5 seconds to enter reset mode. Verify the admin password or fingerprint on the keypad. If correct, the lock will reset to factory settings and erase all data.
2. If bound only to Matter ecosystem: Press and hold the lock button and confirm button on the keypad for 5 seconds to enter reset mode. Then press and hold the reset button on the lock for 3 seconds. The lock will reset to factory settings and erase all user data.

Exclusive Features

We recommend using the Aqara Home app to access exclusive features and detailed settings such as Manual Calibration, Auto Lock, Auto-Turn Lock/Turn to Lock, Pull Spring Feature, and more. Our Manual Features like Away Mode, Night Latch Mode, Auto Unlock Mode, and others will be gradually rolled out via OTA updates around the end of H2 2024 through Aqara Home app.

Reset Smart Lock U200

- 1. Aqara Home Users**
 - 1) Press and hold the Lock and Confirm buttons on the keypad simultaneously for 3 seconds to enter Reset Mode.
 - 2) After the prompt, verify with the admin password or fingerprint. If correct, the lock will clear all user data and restore factory settings.
- 2. Other Matter Ecosystem Users**
 - 1) Press and hold the Lock and Confirm buttons on the keypad simultaneously for 3 seconds to enter Reset Mode.
 - 2) After the prompt, press and hold the Reset button on the lock for 3 seconds. The lock will clear all user data and restore factory settings.

Power Setup

- 1. Door Lock**
The Smart Lock U200 supports charging while in use. Place the charger in the supplied pouch and hang it on the door handle to charge the lock.
- 2. Keypad**
You can use LR3 AAA batteries or have a professional electrician connect a 12V-24V 0.5A AC/DC power supply to your keypad.

FAQ

If you have any other questions about this product, you can find more product information on the following website: <https://www.aqara.com/en/u200-installation-methods>

Online Customer Service: www.aqara.com/en/support.html
 Manufacturer: Lumii United Technology Co., Ltd.
 Address: Room 803-804, Building 1, Chongwen Park, Nanshan IPark, No. 3370, Lixian Avenue, Fuguang Community, Taoyuan Residential District, Nanshan District, Shenzhen, China.
 Email: support@aqara.com